

## DATA SHEET

# SP860A CENTRAL SPEAKER SYSTEM

Recreational Facilities  
Transportation Terminals  
Convention Centers  
Correctional Facilities  
Warehouse/Factories  
Community Halls  
Gymnasiums  
Sports Arenas  
Shopping Malls  
Super Stores  
Restaurants  
Theatres  
Schools  
Churches

**Octasound®**  
S O U N D A B O V E A L L



### FULL FIDELITY - FOR BOTH VOICE AND MUSIC

The KDM SP860A is a full fidelity (20 Hz to 20 kHz) Central Speaker System. The KDM SP860A tuned port enclosure contains a highly efficient 18" woofer matched to four compression horns and drivers. The frequency spectrum of the woofer and horns is determined by an internal crossover network that is optimized to maximize performance. This combination ensures full fidelity reproduction from an extremely compact central speaker system.

### HIGH SENSITIVITY - 104 dB PER WATT PER METER

The KDM SP860A is extremely sensitive with a Sound Pressure Level (S.P.L.) of 104 dB per watt at 1 meter, hence very little amplifier power is required to obtain the required sound pressure levels. At maximum RMS input power the KDM SP860A can produce 128 dB S.P.L. at one meter.

### HIGH POWER HANDLING - 350 WATTS RMS / 700 WATTS PEAK

The KDM SP860A can withstand input power of 350 watts RMS. The KDM SP860A also contains a built-in, self-resetting thermal protective circuit. This protects the high frequency drivers from excessive and distorted (10% T.H.D.) input levels.

### WIDE COVERAGE AREA - 360° X 180°

The KDM SP860A provides coverage over a 360° Horizontal and 180° Vertical plane. These wide dispersion characteristics will permit a large area to be covered by a single KDM SP860A.

### SMALL AND COMPACT - 16 INCHES HIGH / 105 LBS

The KDM SP860A is only 16 inches (40.6 cm) high and weighs 110 lbs (50 kg). The KDM SP860A can be installed in low ceiling areas and close to lights without casting shadows. The low weight permits suspension using readily available hardware such as closed link chains, wire rope etc. The combination of small dimensions and low weight permits the KDM SP860A to be shipped inexpensively.



## Technical Specifications

Frequency Response:	20 Hz to 20 kHz $\pm$ 10 dB (on axis) 35 Hz to 12 kHz $\pm$ 6 dB (on axis)
Optimum Power:	100 to 300 watts RMS total.
Power Handling:	350 watts RMS total, 700 watts peak, (Total Harmonic Distortion less than 10%)
Impedance:	8 ohms nominal.
Dispersion:	360° Horizontal, 180° Vertical. $\pm$ 6 dB Level 100 Hz to 10 kHz.
Sensitivity:	104 dB/watt/meter on axis, pink noise 100 Hz to 10 kHz averaged.
Maximum S.P.L.:	128 dB RMS / 131 dB Peak at 1 meter.

*Octasound Speakers and Sound System Modules are manufactured by the award winning company KDM Electronics Inc. With over 25 years of experience, KDM can design a turn-key sound system to meet or exceed your sound requirements.*

by KDM Electronics

# SP860A CENTRAL SPEAKER SYSTEM

## Physical Specifications

Temperature Range:	-20°C to 55°C (-4°F to 131°F)
Humidity Range:	0% to 100% Non Condensing
Dimensions:	See Diagrams (Not to Scale, Tolerance $\pm 1/4"$ )
Weight:	110 lbs (50 kg)
Material:	Moisture Resistant Wood Composite Panel
Mounting Hardware:	Four 1 1/2" Eye Nuts, 3/4" I.D. Eye 1/4 x 20 Thread
Shipping Weight:	145 lbs (65.8 kg)
Shipping Dimension:	40" (101.6cm) Square, by 24" (61cm) high

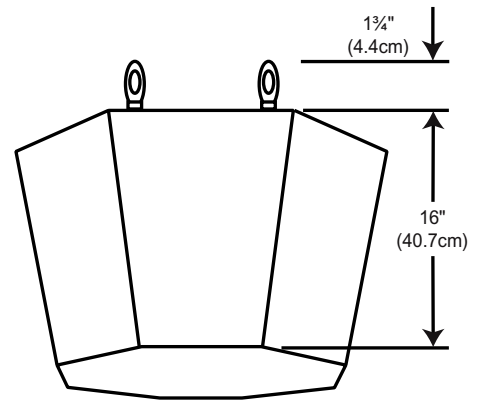

Side View

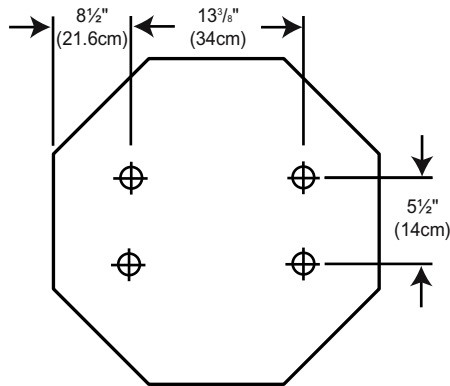

Mounting Hardware Dimensions

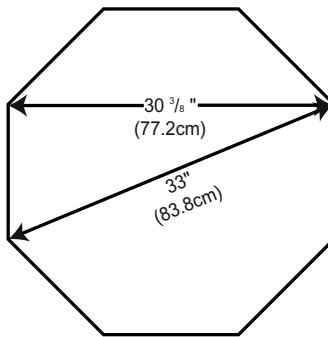

Top View

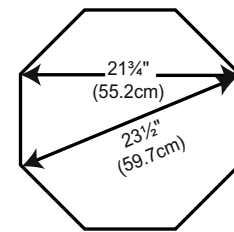

Bottom View

## Architects and Engineers Specifications

The loudspeaker shall be an octagonal shaped speaker containing a 18" (457 mm) diameter, low frequency driver, with a 4" (102mm), 8 ohm voice coil, and a magnet weight of 120 ounces (3.4 kg) minimum, plus, four high frequency 9 1/2" x 7 3/4" (241 mm x 197 mm) wide dispersion exponential compression horns & drivers with a 1 3/4" (44 mm) diameter voice coil manufactured in CCAW (Copper Clad Aluminum Wire) Kapton® former and a barium ferrite magnet that weighs 24 ounces (665 g) minimum and contains an injected phase plug optimized to eliminate undesirable phase cancellations. The horns and drivers shall have a 1" (25 mm) throat diameter, titanium diaphragm and Kapton® bobbin to reduce over heating and voice coil rub. These components shall all be contained within a tuned port bass enclosure. The sensitivity shall be 104 dB per watt per meter. The overall speaker system shall contain one crossover network that separates the low and high frequency spectrum at a crossover point of 2 kHz  $\pm 15\%$ . The internal crossover shall have a built in thermal protective circuit to prevent damage from occurring at power levels up to 700 watts of peak power. The overall speaker system shall be capable of withstanding power levels up to 350 watts RMS, with a total harmonic distortion of less than 10%. The total impedance of the speaker system shall be 8 ohms nominal. The speaker shall contain a perforated metal speaker grill to protect the bass speaker. The enclosure shall be manufactured from 3/4" (19 cm) moisture resistant wood composite with all joints secured with moisture resistant glue. A sealant, primer and durable industrial textured finish shall be applied to the enclosure. All exposed metal must be aluminum, stainless steel, plated or painted. Four 1 1/2 inch eye nuts shall be provided for mounting. The complete speaker shall weigh a maximum of 110 lbs. (50 kg), with the following maximum dimensions: top width 33" (83.8 cm), bottom width 23 1/2" (59.7cm) and height 16" (40.7 cm) + 1 3/4" (4.4 cm) for mounting hardware.

**The loudspeaker shall be KDM Electronics Incorporated Model SP860A**

## Ordering Information

**SP860A - XX** (where XX specifies color). **WH**=White Low Sheen Splatter Finish (Standard), **BK**=Black low sheen Splatter Finish  
Other colors available upon request. Additional charges may apply.

KDM Electronics Inc. reserves the right at any time to make changes in product design, components and specifications, as may be warranted by progress in technology.



**Octasound**  
SOUND ABOVE ALL

KDM Electronics Inc.  
931 Progress Avenue, Unit #12  
Toronto, Ontario  
Canada, M1G 3V5

Tel: (416) 439-7158  
Toll Free: 1-800-567-6282  
Fax: (416) 439-7232  
Web Site: [www.octasound.com](http://www.octasound.com)  
E-Mail: [kdm@octasound.com](mailto:kdm@octasound.com)