

Octasound RAMX2 V2.0 - Setting the Jumpers

The first requirement for the RAMX2 to work according to your installation is to set the jumpers according to the charts below. With the new version of the mixer you can have a line level output on channel 2. This will allow you to use channel 2 into a separate amplifier without the RAMX2 controlling the volume. This feature can be used where you do not want the user of the mixer varying the volume in another zone such as a viewing area or a hearing assist system.

Octasound RAMX2 Jumper Settings JP1 and JP6 2 Possible Configurations

JP1 and JP6 control output channel 1 (pins 5 and 6) and output channel 2 (pins 7 and 8) signals. They can be set as variable, volume control of the mixer controls the volume. Or they can be set as fixed, volume control of the mixer has no affect. There are 5 Different Configurations.

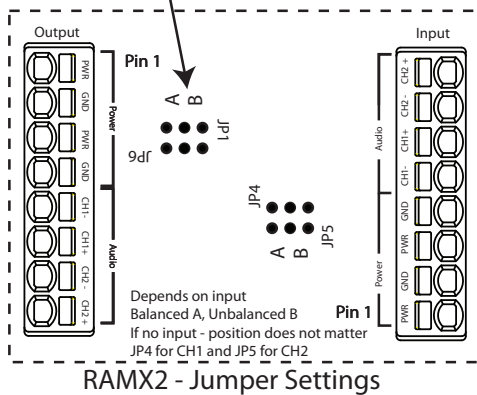

- Factory Default**
Mic and Aux output variable on channel 1
Mic and Aux fixed level on channel 2
- Aux output variable on channel 1
Mic output variable on channel 2

JP4 and JP5 are set according to channel 1 and channel 2 inputs. JP4 controls channel 1 and JP5 controls channel 2. If you are not using the input connector then these settings are not required. There are 4 possible settings.

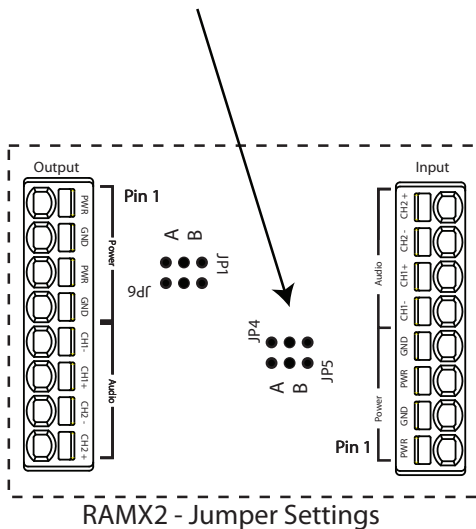

- Factory Default**
Channel 1 input is balanced. Channel 2 input is balanced
- Channel 1 input is unbalanced. Channel 2 input is unbalanced
- Channel 1 input is balanced. Channel 2 input is unbalanced
- Channel 1 input is unbalanced. Channel 2 input is balanced

To take full advantage of the feature set provided by the Octasound RAMX2 it is recommended to use CAT5 for wiring. Other methods will restrict the full capability. See page 2 and 3 for alternate wiring methods.

Wiring The Octasound - RAMX2 Output CAT5 Method - Single or Dual Channel

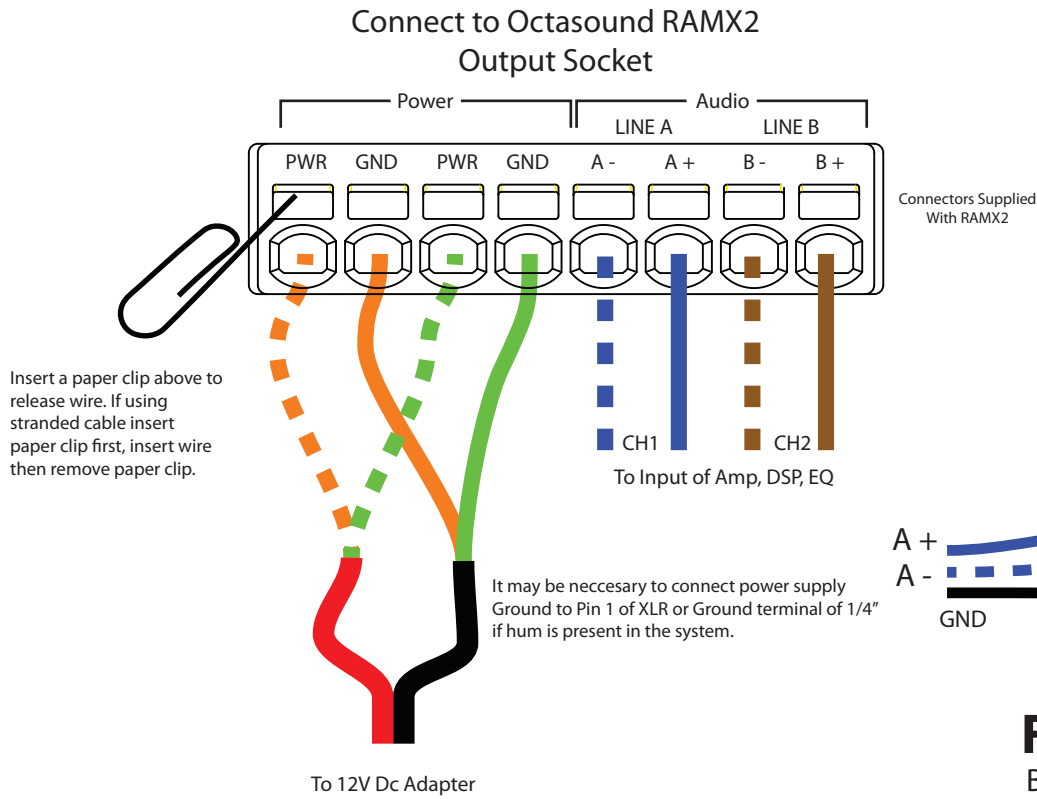

Connect XLR to Input of Amp, DSP, EQ
Wiring LINE A to an XLR
(Rear View)

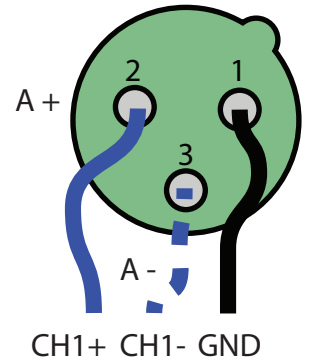

Wiring LINE A to an 1/4" Jack

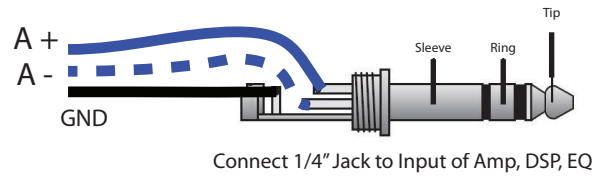
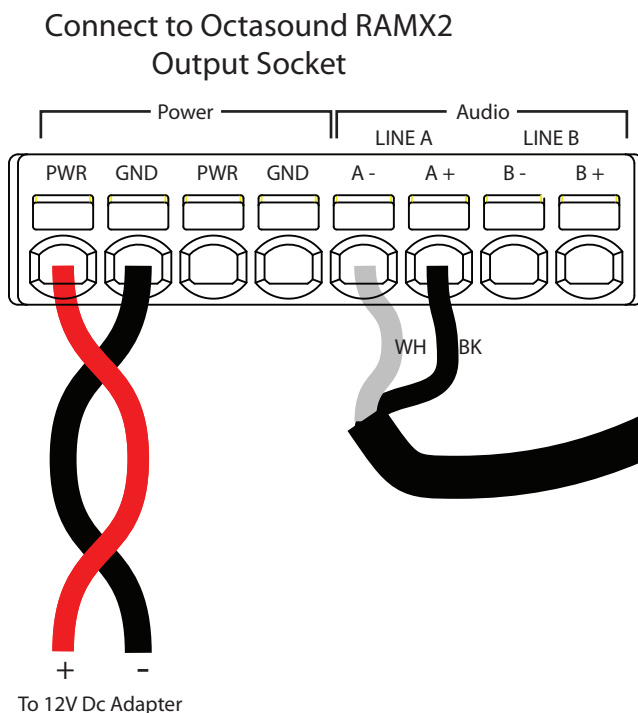
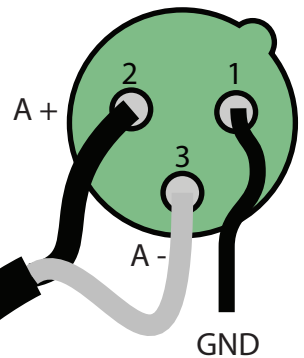

FIGURE A
Balanced Output

Wiring The Octasound - RAMX2 Output 2 Conductor Shielded Cable + Power Cable



Connect XLR to Input of Amp, DSP, EQ
Wiring LINE A to an XLR
(Rear View)



or wiring LINE A to an 1/4" Jack

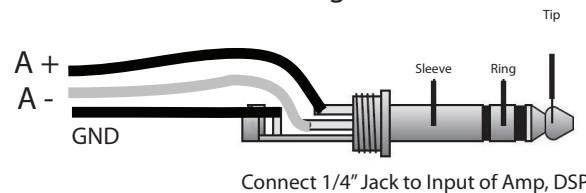
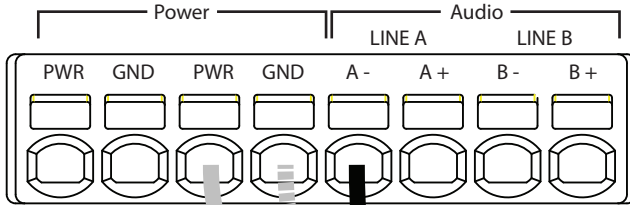

FIGURE B
Balanced Output

Wiring The Octasound - RAMX2 Output With Only 2 Conductor Shielded Cable

FIGURE C
Unbalanced Output

Connect to Octasound RAMX2
Output Socket



Connectors Supplied
With RAMX2

WH SH BK

****** Wire shielded cable in parallel to negative power supply
And ground on unbalanced amplifier input**

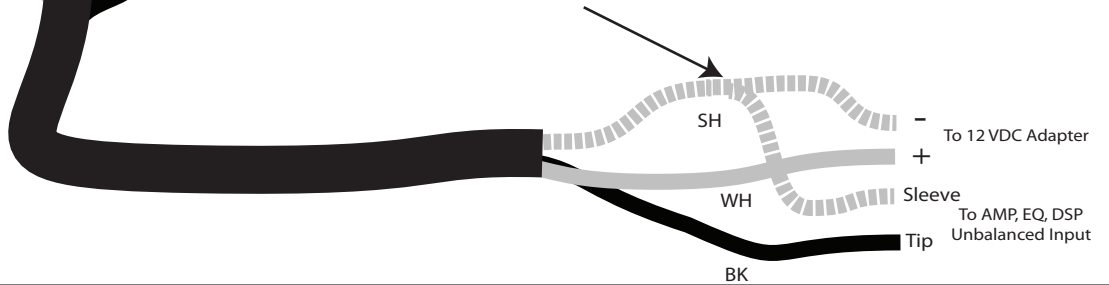

Wiring The Octasound - RAMX2 Output Into a KDM IA330A, MI300

FIGURE D
Unbalanced Output

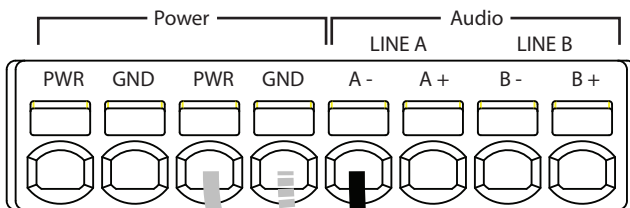

WH SH BK

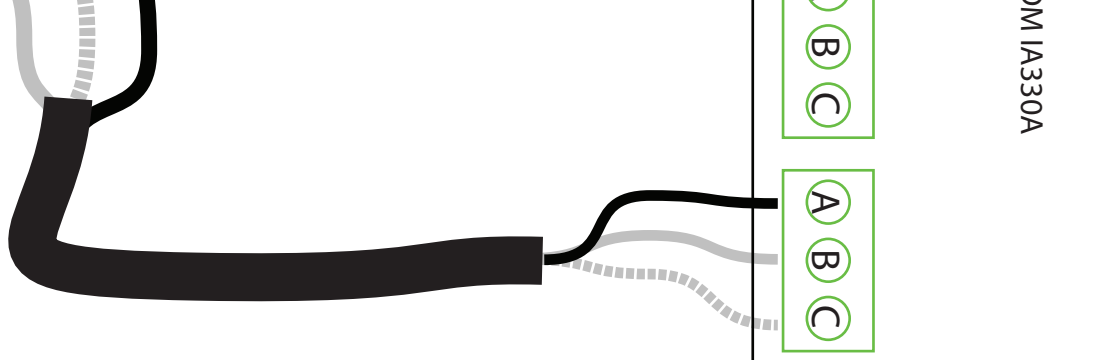

Daisy Chaining the Octasound - RAMX2 Using Cat 5 Cable

**** If you require separation of Aux to CH1 and MIC to CH2 - JP1 must be in the B position on all RAMX2 Mixers

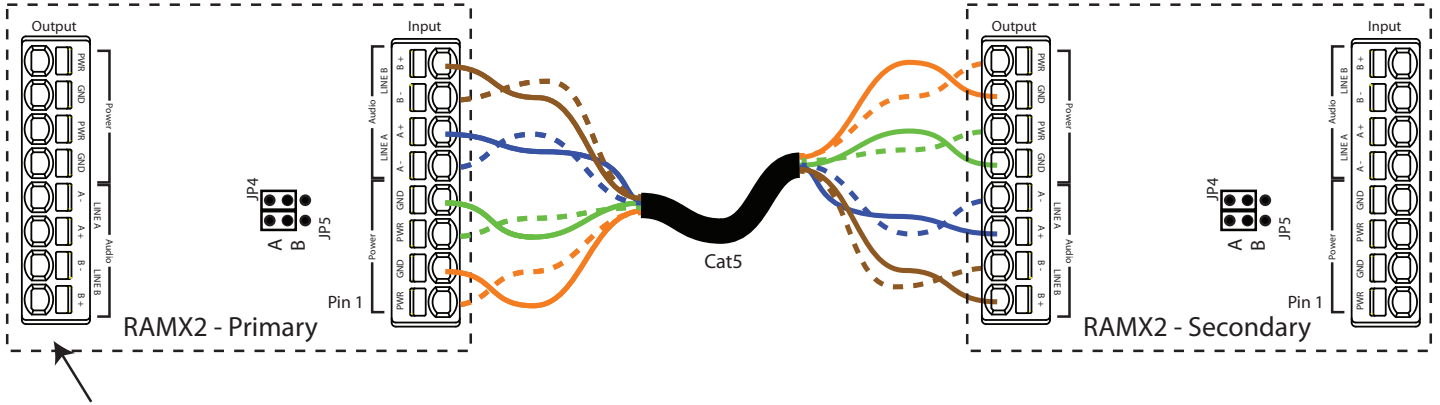

Refer to Figure A ,B or C for Choosing an Output Wiring Method to Amp, EQ, DSP. Primary RAMX2 must be powered.

Daisy Chaining the RAMX2 Using Twisted Pair Shield Cable + Power

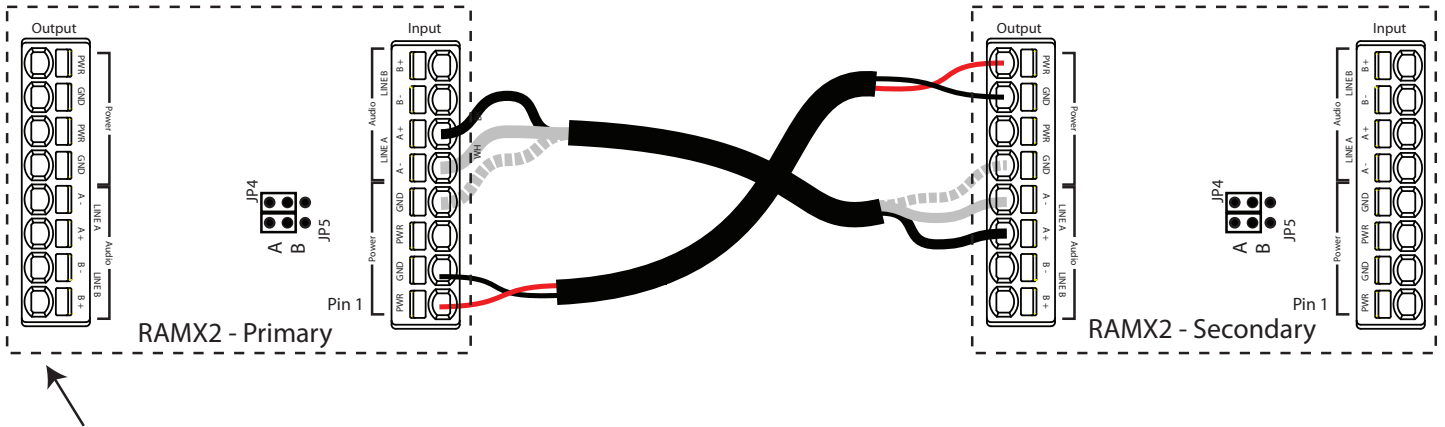

Refer to Figure A ,B, C or D for Choosing an Output Wiring Method to Amp, EQ, DSP. Primary RAMX2 must be powered.

Daisy Chaining the RAMX2 Using Twisted Pair Shield Cable

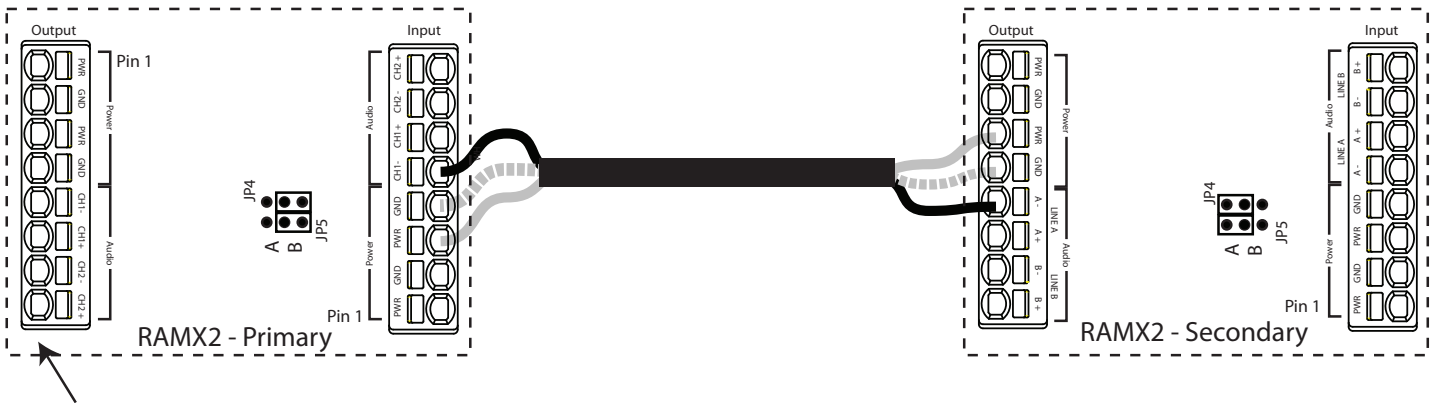

Refer to Figure A ,B, C or D for Choosing an Output Wiring Method to Amp, EQ, DSP. Primary RAMX2 must be powered.

Replacing a MX120A with an Octasound - RAMX2 in an existing MX120A installation

**** Note the Octasound RAMX2 must be the first (primary) mixer in the chain of mixers. This may require moving existing mixers

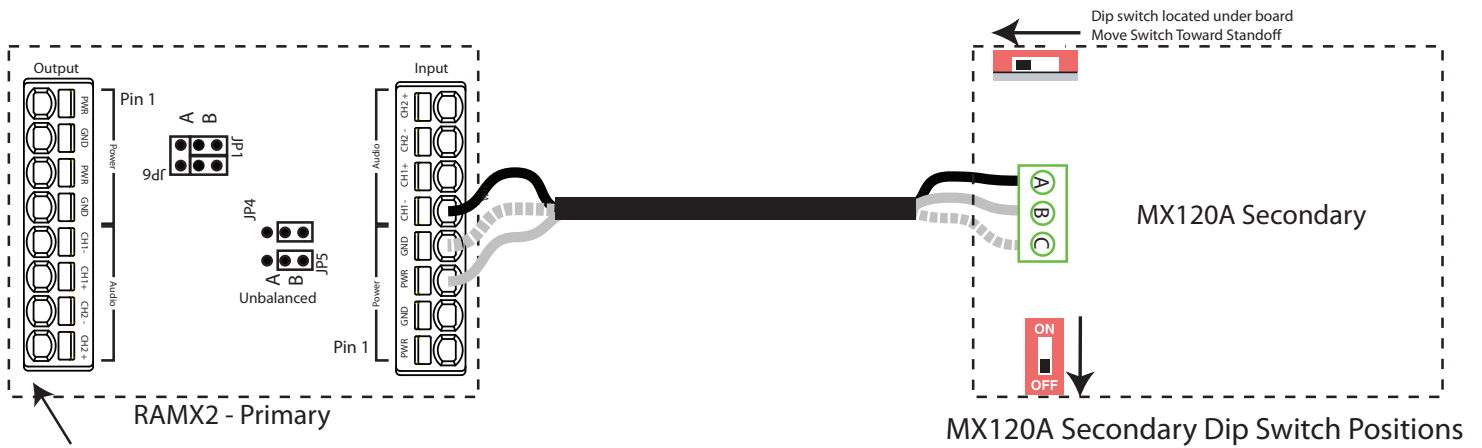

Refer to Figure A ,B or C for Choosing an Output Wiring Method to Amp, EQ, DSP. Primary RAMX2 must be powered.

Adding an Octasound RAMX2 into an existing MX120A Installation

Disconnect the MX120A from the amplifier and splice onto the CAT5 cable used on the RAMX2 as per diagram.
At the RAMX2 location - Wire the Brown and Brown White wire to the RAMX2 input connector.

